

The Opto-Mechanical Design of the GMT-Consortium Large Earth Finder (G-CLEF)

Mark Mueller^a, Andrew Szentgyorgyi^a, Daniel Baldwin^a, Jacob Bean^b, Sagi Ben-Ami^a, Patricia Brennan^a, J. Budynkiewicz^a, Moo-Yung Chun^c, Jeffrey D. Crane^c, Harland Epps^g, Ian Evans^a, Janet Evans^a, Jeff Foster^a, Anna Frebel^f, Thomas Gauron^a, Alex Glenday^a, Tyson Hare^c, Bi-Ho Jang^e, Jeong-Gyun Jang^e, Andres Jordan^d, Jihun Kim^e, Kang-Min Kim^e, Claudia Mendes de Oliveira^h, Mercedes Lopez-Morales^a, Kenneth McCracken^a, Stuart McMuldroy^a, Joseph Miller^a, Jae Sok Oh^e, Cem Onyuksel^a, Mark Ordway^a, Chan Park^e, Sung-Joon Park^e, Charles Paxson^a, David Phillips^a, David Plummer^a, William Podgorski^a, Andreas Seifahrt^b, Joao Steiner^h, Alan Uomoto^b, Ronald Walsworth^a, Young-Sam Yu^c

^aHarvard-Smithsonian Center for Astrophysics, 60 Garden St., Cambridge, MA 02140;

^bUniversity of Chicago, 640 S. Ellis Ave, Chicago, IL 60637;

^cThe Observatories of the Carnegie Institution for Science, 813 Santa Barbara St., Pasadena, CA 91101;

^dPontificia Universidad Católica de Chile, Vicuna Mackenna 4860, Macul, Santiago, Chile;

^eKorea Astronomy and Space Science Institute (KASI), 776 Daedeokdae-ro, Yuseong-gu, Daejeon, Republic of Korea

^fMassachusetts Institute of Technology, Department of Physics, 77 Massachusetts Avenue, Cambridge, MA 02139

^gUniversity of California, Lick Observatory, Santa Cruz, CA 95064

^hInstitute of Astronomy, Geophysics and Atmospheric Sciences, University of Sao Paulo, Street Matão, 1226, 05508-090 Sao Paulo, Brazil

ABSTRACT

The GMT-Consortium Large Earth Finder (G-CLEF) is a fiber-fed, optical echelle spectrograph selected as the first light instrument for the Giant Magellan Telescope (GMT) now under construction at the Las Campanas Observatory in Chile. G-CLEF has been designed to be a general-purpose echelle spectrograph with precision radial velocity (PRV) capability for exoplanet detection. The radial velocity (RV) precision goal of G-CLEF is 10 cm/sec, necessary for detection of Earth-sized exoplanets¹. This goal imposes challenging stability requirements on the optical mounts and the overall spectrograph support structures especially when considering the instrument's operational environment. The accuracy of G-CLEF's PRV measurements will be influenced by minute changes in temperature and ambient air pressure as well as vibrations and micro gravity-vector variations caused by normal telescope slewing. For these reasons we have chosen to enclose G-CLEF's spectrograph in a vibration isolated vacuum chamber, within a well-insulated thermal enclosure, at a gravity invariant location on GMT's azimuth platform. Additional design constraints posed by the GMT telescope include: a limited space envelope, a thermal emission ceiling, and a maximum weight allowance. Other factors, such as manufacturability, serviceability, available technology and budget are also significant design drivers. All of the above considerations must be managed while ensuring performance requirements are achieved.

In this paper, we discuss the design of G-CLEF's optical mounts and support structures including the choice of a low coefficient of thermal expansion (CTE) carbon-fiber optical bench to minimize the system's sensitivity to thermal soaks and gradients. We discuss design choices made to the vacuum chamber geared towards minimize the influence of daily ambient pressure variations on image motion during observation. We discuss the design of G-CLEF's insulated enclosure and thermal control systems which will maintain the spectrograph at milli-Kelvin level stability while simultaneously limiting thermal emissions into the telescope dome. Also discussed are micro gravity-vector variations caused by normal telescope slewing, their uncorrected influence on image motion, and how they are dealt with in the design. Finally, we discuss G-CLEF's front-end assembly and fiber-feed system as well as other interface challenges presented by the telescope, enclosure and neighboring instrumentation.

Keywords: Echelle spectrograph, precision radial velocity, G-CLEF, GMT, optical mounts, vacuum chamber

1. INTRODUCTION

G-CLEF is the GMT-Consortium Large Earth Finder. It will be the first light science instrument on the GMT². G-CLEF is an optical-band, fiber-fed echelle spectrograph with a working passband of 3500Å-9000Å. It is being built by a consortium of institutions consisting of the Harvard-Smithsonian Center for Astrophysics, Carnegie Observatories, Pontificia Universidad Catolica de Chile, the Korean Astronomy and Space Science Institute and the University of Chicago. G-CLEF is been optimized to have extreme PRV measurement capability needed to satisfy a critical science goal of measuring the mass of an earth-sized rocky exoplanet orbiting a solar-type star in that star's habitable zone . In order to maximize mechanical and thermal stability, it is vacuum enclosed and will be operated at a gravity invariant location on the telescope structure. The spectrograph features an asymmetric white pupil design³ with a 300 mm diameter beam that is reduced to 200 mm with a pupil transfer mirror after dispersion by the echelle grating. We are currently in the critical design phase. The instrument Preliminary Design Review was held in April 2015. Science operations are planned to begin in 2021.

The GMT is a 25.4 m diameter optical and near infrared (NIR) telescope under construction in Las Campanas, Chile⁴. The telescope is built around a segmented primary mirror design composed of seven 8.4m diameter mirrors and will have a collecting area roughly three times larger than the largest filled aperture, optical-NIR telescopes in operation today.

G-CLEF combined with the GMT will be a powerful instrument for a broad range of investigations in stellar astrophysics, cosmology and astrophysics in general.

2. G-CLEF INSTRUMENT DESIGN

G-CLEF's opto-mechanical design is being developed in response to a requirements flow-down from the GMT and G-CLEF scientific objectives³. There are broad statements of the science drivers for the GMT and G-CLEF. These Level 0 science drivers are quantified into Science and Operational requirements for the GMT and G-CLEF. The GMT overall System Level Requirements reside at Level 2, and the GMT major subsystem (Telescope, Software, Adaptive Optics, Instrumentation and Operations) requirements are at Level 3. The GMT Level 3 Instrumentation requirements and the G-CLEF Science requirements flow down into the Level 4 G-CLEF Instrument Design Requirements⁵.

2.1 G-CLEF Instrument System Engineering Requirements

GMT Instrumentation Requirements and G-CLEF Science Requirements flow down into the G-CLEF Instrument System Design Requirements, which are defined at Level 4 in the GMT Requirements Management System. The resulting document is the G-CLEF System Requirements Specification, which captures the top level G-CLEF design requirements. Table 1 provides a summary of the major requirements for G-CLEF. The requirements reflect the multiple uses of G-CLEF for both PRV measurements and for more general high resolution visible band spectroscopy. To meet the multiple science objectives, G-CLEF must have a broad passband, high resolution, high throughput and a PRV capability. G-CLEF will support four different resolution modes, using two science cameras, one for the blue wavelengths and another for the red. The performance requirements are therefore specified as a function of mode, and the throughput as a function of both mode and wavelength.

Table 1- Summary of Primary G-CLEF Instrument Requirements

Requirement Title	Requirement Statement
Seeing Conditions	Meet requirements at GMT 75 th percentile seeing, with a full width half maximum (FWHM) of 0.79 arc seconds
Optical Feed	Provide an optical feed which deploys into the telescope beam and relays light into the G-CLEF Fiber Feed System
Flexure and Defocus Detection	Provide an instrument flexure and defocus sensing system which measures flexure-induced telescope to instrument guide and focus offsets. Send these offsets to the GMT telescope Control System for correction

Instrument Passband	3500Å to 9000Å simultaneous wavelength coverage																														
Measurement Modes and Spectral Resolution	Optically Scrambled Precision Radial Velocity mode (PRV) with Spectral Resolution = 108,000 (Pupil Sliced) High Throughput, non-scrambled PRV Mode (PRV-NS) with Spectral Resolution = 108,000 (Pupil Sliced) High Throughput (HT) Mode with Spectral Resolution = 20,000 Medium Throughput (MT) Mode with Spectral Resolution = 35,000																														
Estimated Instrument Throughput (Includes all pre-optics and fiber run, excludes the telescope. Assumes 75% seeing or 0.79" and a Gaussian PSF)	<table border="1"> <thead> <tr> <th>Wavelength(nm)</th> <th>HT</th> <th>MT</th> <th>PRV</th> <th>PRV-NS</th> </tr> </thead> <tbody> <tr> <td>350</td> <td>7.7%</td> <td>4.9%</td> <td>3.8%</td> <td>4.7%</td> </tr> <tr> <td>500</td> <td>16.2%</td> <td>10.3%</td> <td>8.1%</td> <td>10.1%</td> </tr> <tr> <td>650</td> <td>15.0%</td> <td>9.6%</td> <td>7.6%</td> <td>9.4%</td> </tr> <tr> <td>800</td> <td>14.2%</td> <td>9.0%</td> <td>7.1%</td> <td>8.8%</td> </tr> <tr> <td>900</td> <td>8.5%</td> <td>5.4%</td> <td>4.3%</td> <td>5.3%</td> </tr> </tbody> </table>	Wavelength(nm)	HT	MT	PRV	PRV-NS	350	7.7%	4.9%	3.8%	4.7%	500	16.2%	10.3%	8.1%	10.1%	650	15.0%	9.6%	7.6%	9.4%	800	14.2%	9.0%	7.1%	8.8%	900	8.5%	5.4%	4.3%	5.3%
Wavelength(nm)	HT	MT	PRV	PRV-NS																											
350	7.7%	4.9%	3.8%	4.7%																											
500	16.2%	10.3%	8.1%	10.1%																											
650	15.0%	9.6%	7.6%	9.4%																											
800	14.2%	9.0%	7.1%	8.8%																											
900	8.5%	5.4%	4.3%	5.3%																											
Brightness Limit	Function with target brightness of $M_R = 6$ (or fainter)																														
Atmospheric Dispersion Compensation	Provide on-instrument atmospheric dispersion compensation																														
Operating Air Mass	Operate in all modes with air mass ≤ 2																														
PRV Measurement Precision	Capable of making single PRV measurements with a radial velocity single measurement precision of 40 – 50 cm/second with a goal of 10 cm/second.																														

2.2 G-CLEF Spectrograph Optical Design

The spectrograph optical layout is shown in figure 1. Emerging from the fiber feed and passing through a focal ratio converter, an f/8 beam follows the following optical path:

1. Reflected off an off-axis parabolic collimator
2. Reflected and dispersed from the Echelle grating
3. Reflected (2nd pass) off the off-axis parabolic collimator and focused
4. Reflected off a cylindrical Mangin fold mirror
5. Reflected and collimated off an elliptical transfer mirror (M2)
6. Red wavelengths are transmitted, Blue reflected by a dichroic into separate Blue and Red camera systems
7. Each band passes through separate Blue or Red cross-dispersers
8. Each band passes separately through a multi-lens camera (Blue and Red)
9. Each band is imaged by a 90 mm X 90 mm CCD (Blue and Red)

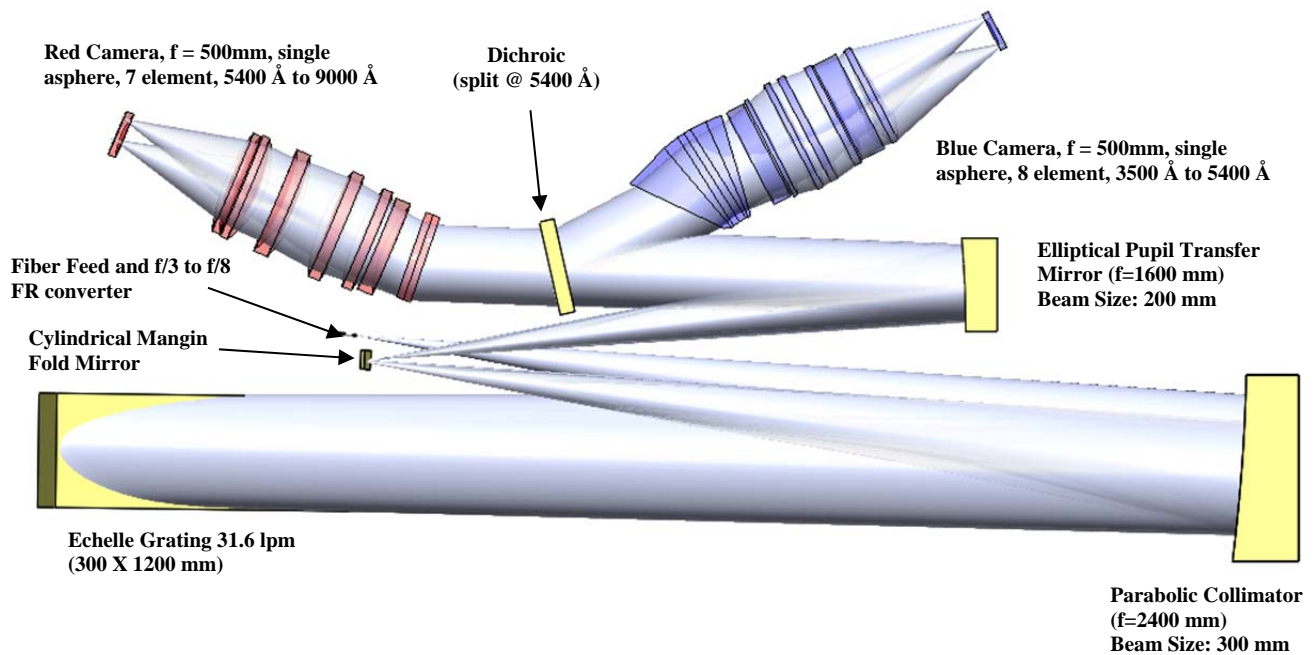

Figure 1 - Spectrograph Optical Layout

2.3 Instrument Subsystems

2.3.1 Front End System

The front end subsystem layout is shown in figure 2. The function of the front end is to extend into the telescope optical beam, pick-off a 1.5 arc minute field of view and relay it to the slit apertures which feed the fiber system. The front end sits on top of the Gregorian Instrument Rotator (GIR) which resides just below the primary mirror cells.

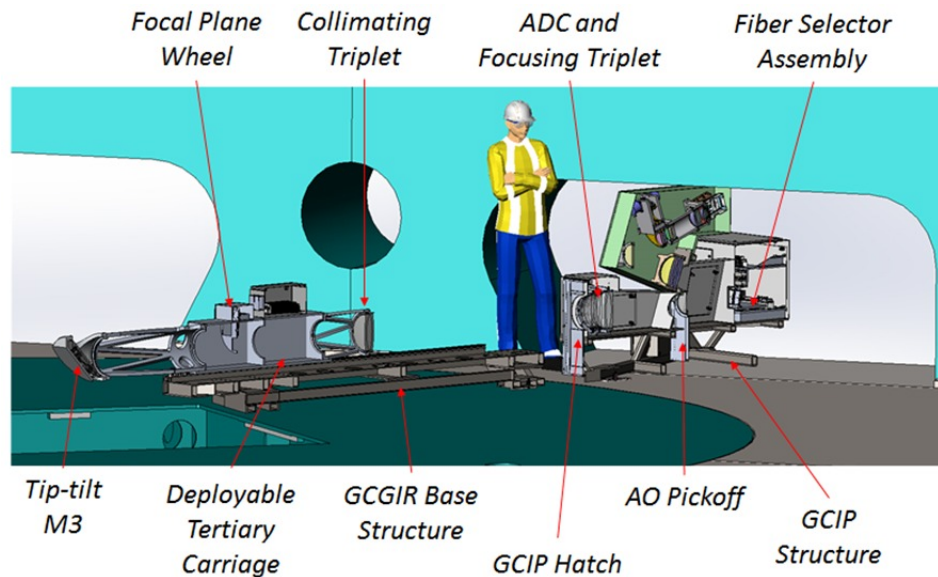

Figure 2 – Front End Assembly Mounted to the Top of GMT's Gregorian Instrument Rotator

The front end contains the following:

- a.) Pick-off tertiary mirror with tip-tilt capability for flexure compensation
- b.) Relay optics (Collimating and Focusing Triplets)
- c.) Atmospheric Dispersion Compensation (ADC) Prism Assemblies
- d.) Calibration system input fiber mechanism
- e.) Slit plane and fiber/operational mode selector
- f.) Guide camera
- g.) Focus sensor

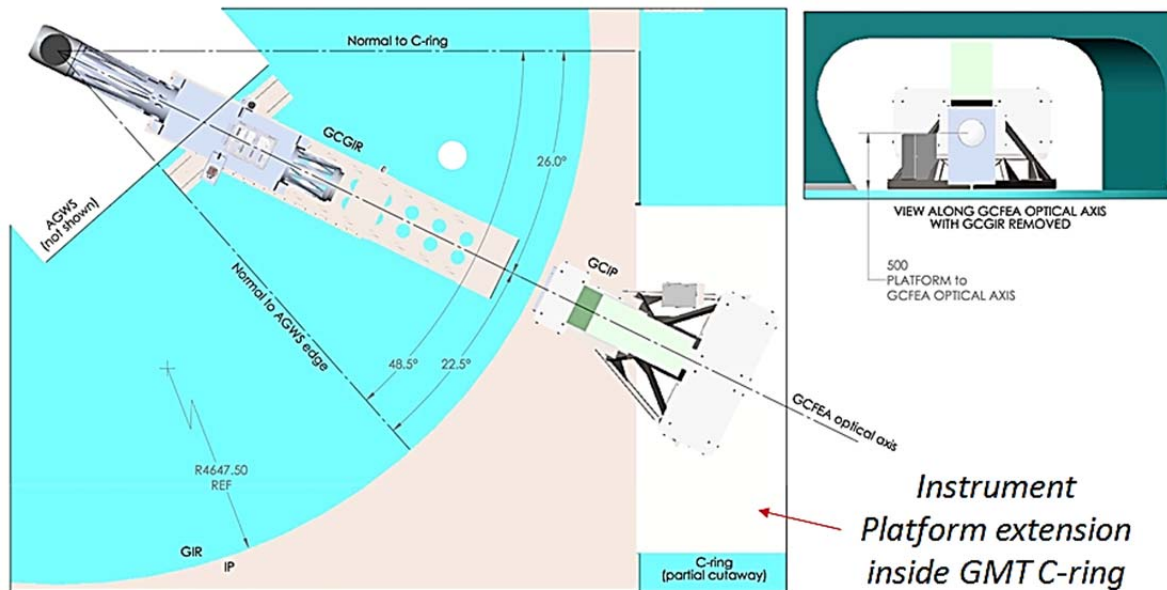

Figure 3 – Front End GIR and IP Portions – Overhead View

The front end has been allocated a space on the upper portion of GMT's GIR and Instrument Platform (IP) as shown in figure 3. It uses one-half of a GIR quadrant. The IP portion is centered with the telescope's C-ring cavity. Precise GIR to IP alignment will be required. The front end will be in close proximity with other, yet to-be-defined instrumentation and therefore the front-end design team is working to an interface envelope with a weight budget.

2.3.2 Fiber System

The fiber system includes the optical fibers and associated components which relay the light from the slit aperture into the spectrograph. The fiber system is routed as shown in figure 4 uses an IGUS cable chain to accommodate changes in telescope elevation.

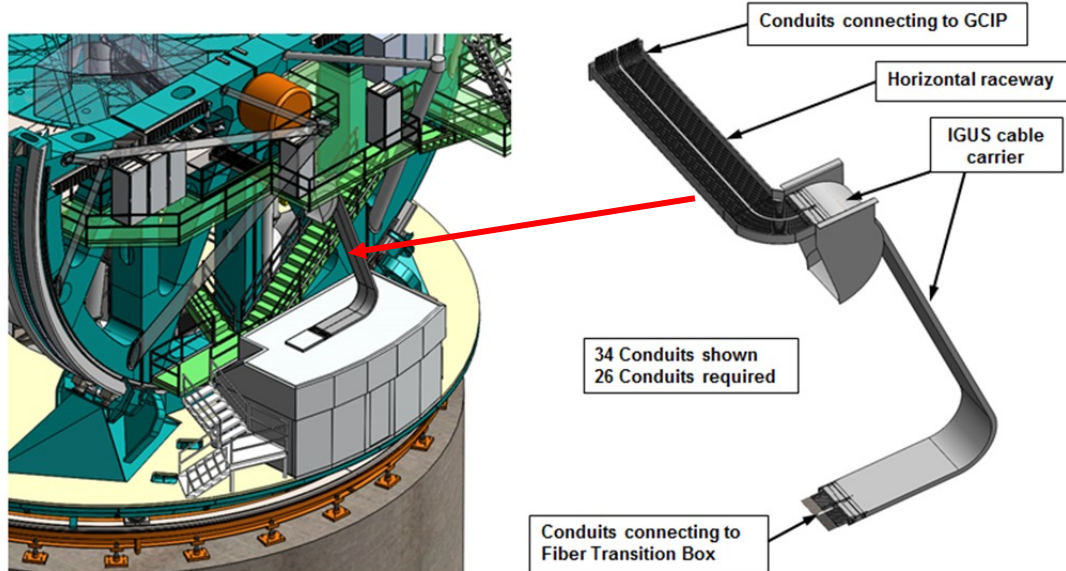

Figure 4 – Fiber Routing

2.3.3 Spectrograph

2.3.3.1 Optical system

The optical system shown previously in figure 1 is the heart of the spectrograph and is supported on an optical bench within a temperature controlled vacuum chamber. Considering G-CLEF's challenging PRV requirement, environmental factors such as temperature, vibration, ambient pressure variation and micro gravity vector variations due to telescope motion must be mitigated to a high level of precision.

2.3.3.2 Optical Bench

The optical system is highly sensitive to relative motion of the optics caused by even minute changes in temperature. Our derived thermal requirement is to control the internals of the vacuum chamber (primarily the optical system and bench) to a target temperature $(20\text{ }^{\circ}\text{C}) \pm 0.001\text{ }^{\circ}\text{C}$. Even with this level of temperature control, system modeling predicts that if the optical bench were constructed of a more traditional low-CTE material such as Invar, image motion at the detector (IMAD) would not allow us to achieve our PRV measurement goal of 10 cm/s.

When exposed to thermal soaks, and gradients of $.001^{\circ}\text{K}$, IMAD for different materials is:

- Carbon fiber bench with Invar optical mounts = 6.5 \AA (3.25 cm/s) – **Within budget allocation of 10 \AA**
- Invar bench with Invar optical mounts = 64 \AA (32 cm/s) – **6X budget allocation**
- Mild steel bench with optical mounts = 632 \AA (316 cm/s) – **63X budget allocation**

Our systems engineering image motion allocation for thermal stability is 10 \AA (5 cm/sec). NOTE: Entire instrument calibratable error allocation is 28 \AA (14 cm/sec)

Steel has been used successfully on HARPS/ESPRESSO but there are key differences worth noting. They include:

- HARPS/ESPRESSO: ESPRESSO bench mass is $\sim 4000\text{ kg}$ = High thermal inertia achieved with the addition of significant mass which is not desirable for G-CLEF due to its location in the azimuth platform.
- HARPS/ESPRESSO is directly coupled to ground in an enclosed/stationary environment. Temperature variation of surroundings is low. G-CLEF will be installed on the telescope Azimuth (AZ) platform and exposed to ambient temperature from above and below ($-5\text{ to }25\text{ }^{\circ}\text{C}$).

For these reasons it is necessary for G-CLEF to utilize a bench design less sensitive to thermal soaks and gradients. A steel bench is 100X more sensitive to thermal gradients than a carbon fiber reinforce polymer (CFRP) bench. This advantage is 10X for an Invar bench but the cost delta of Invar vs CFRP is less pronounced. Adding mass as a strategy for thermal stability is not an option due to location on AZ platform. For these reasons CFRP is our bench material choice.

There are other considerations with composites that must be considered for our application. They include:

- Coefficient of Moisture Expansion (CME) – Composite structures are hygroscopic. After they are manufactured, these materials absorb ambient moisture and expand as a result. When installed in our vacuum chamber, this moisture will desorb and there will be a corresponding dimensional contraction which will occur over time. We predict that most of this change will occur in the first 100 days. Total dimensional change of bench over the life of the instrument should be between 12 and 49 microns (.0005 - .002”).
- Temporal effects⁶ – Composites experience a natural temporal shrinkage that decreases asymptotically over time. This effect is present in many materials, including Invar, at similar magnitudes and must be accounted for in order to meet our PRV requirement.

2.3.3.3 Optical Mounts

In operation, all G-CLEF mounts benefit from operating at a gravity invariant station, at a stable temperature. Typically the most challenging load condition for all mounts is shipment.

2.3.3.3.1 Camera Mounts

The baseline mounts will be bonded tangential flexures. We selected shipping conditions of 5G's and a temperature range of 5 °C to 25 °C as our survival load conditions. Our research indicated that international shipment options exist, both by sea and air, for which this is a typical controlled temperature range. Our task will be to design suitable shipment isolation to guarantee that expected maximum shipping loads are attenuated to no more than 5G's. Figure 4 shows an example of the relationship between temperature and bonded-mount shock-load capacity for one of our worst-case lenses. The highlighted area shows the target temperature range for shipment. As shown, for this lens we have additional margin to go colder than 5 °C and still maintain of 5G shock capability if needed.

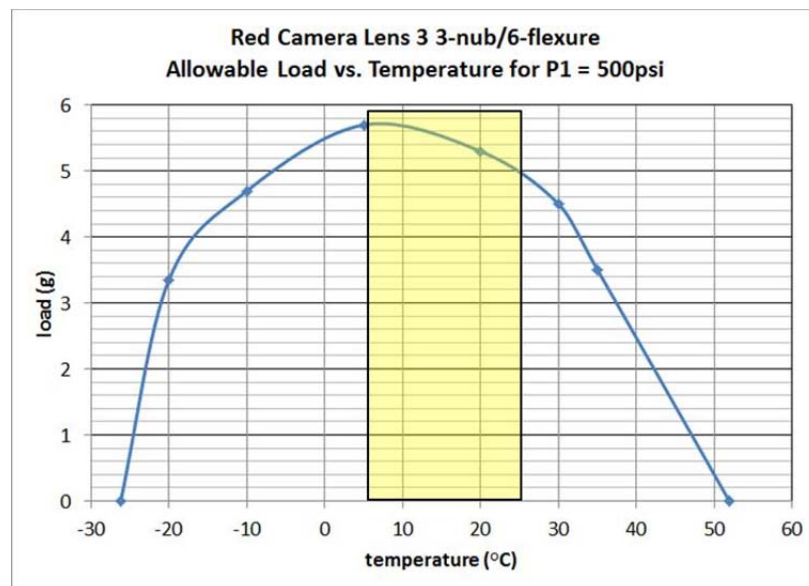

Figure 4 – Shock Load Capacity vs. Shipping Temperature for a Typical Flexured Lens Mount

The current red camera mount design is shown in figure 5.

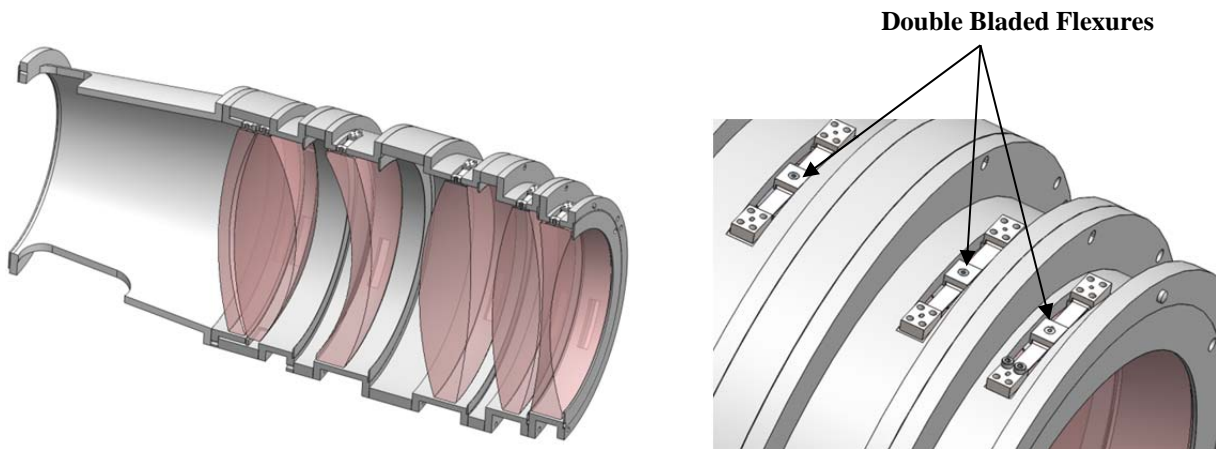

Figure 5 – Red Camera Assembly – Mounted Optics are Stacked Flange-to-Flange

We will mount G-CLEF optics into their associated bezels using a lens alignment and bonding fixture based on the Trioptics-USA Opticentric™ metrology station⁷. This system was developed and refined during mounting of the MMIRS and Binospec optics. It allows registration of an element's optical centerline to the bezel's central axis. This eliminates the need to tightly control the relationship between an optic's optical centerline and its physical outer diameter. The system is shown in figure 6.

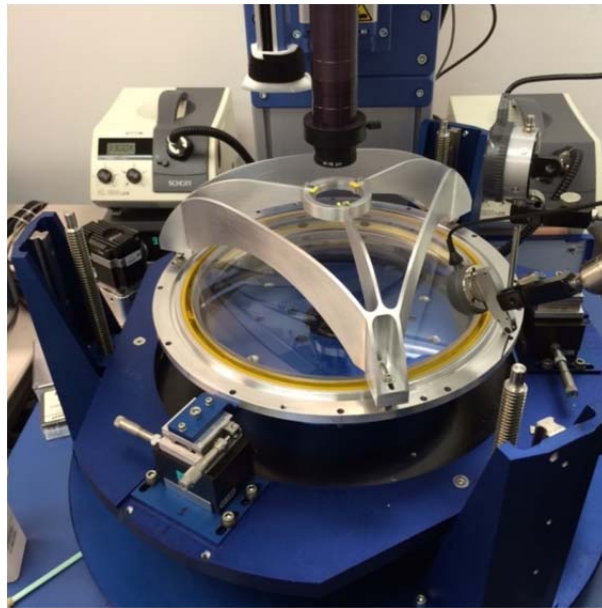

Figure 6 – Opticentric™ System with Axial Positioning Target

2.3.3.3.2 Echelle Grating Mosaic

The G-CLEF optical design features an echelle grating mosaic of three 300mm X 400mm grating facets which must be mounted and aligned relative to one another to tight tolerance. Surfaces must be parallel to one another within approximately 1 arc-second in all axes.

The basic strategy is to fix the central facet (facet 2) kinematically to a stable substrate and then adjust the adjacent facets (facets 1 and 3) with respect to the central facet to the required alignment tolerance. Our initial concept featured solid metallic shims in which adjustments to shim thickness were made by polishing. This was found to be unsatisfactory for a couple of reasons:

- 1.) The required adjustment resolution on shim thickness is on the order of 1 μm . Predictably removing that amount of material via polishing and then verifying it by measurement is an extreme challenge.
- 2.) Adjustment (polishing) of the shims requires disassembly of the facet from the structure. The act of disassembly and reassembly itself introduced errors in alignment which dominated the problem.

In order to mitigate the above challenges, we developed and tested an adjustable shim so that sub-micron adjustments to the facets could be made in situ while measuring alignment using an interferometer. With this design, we were able to easily align facets to within 0.25 arc-second in all axes with demonstrated long term stability of 2 arc-seconds on a bolted together Stainless Steel substrate in a highly variable thermal environment. This stability will improve with a more stable, monolithic substrate in our precision controlled environment.

The grating assembly and adjustable shims are shown in figure 7.

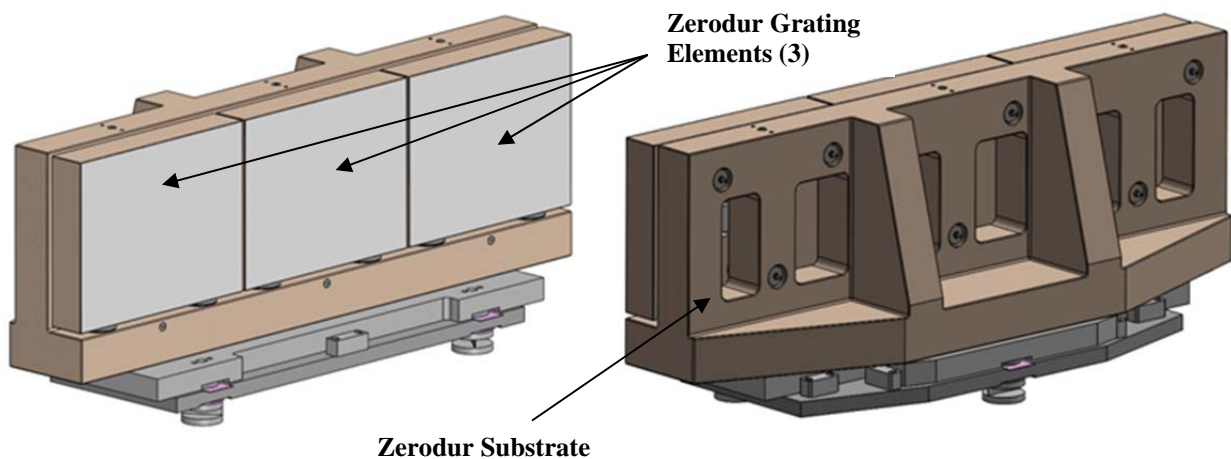

Figure 7 – Grating Mosaic Design with Adjustable Shims

2.3.3.3.3 Mirrors

G-CLEF's mirrors M1, M2 and the Mangin Fold, will be mounted using bonded flexure mounts (see figure 8). Similar flexure mounts were used on the Hectochelle spectrograph.

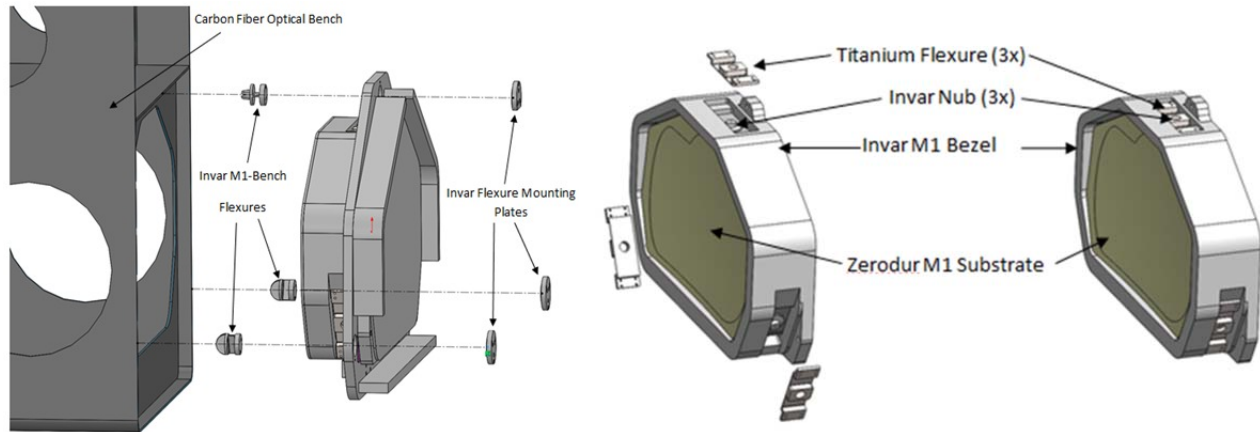

Figure 8 – Typical Mirror Mount – Bonded Flexure Design in Invar Bezel

2.3.4 Vacuum Chamber

The entire spectrograph optical train and optical bench are fully contained within a vacuum chamber. Housing the optics in a vacuum serves a dual purpose. First, in the presence of air, the optical design is sensitive to changes in the refractive nature of air as a function of ambient air pressure. This effect is largely eliminated with operation in a vacuum at levels of 4×10^{-4} Torr or lower. Second, vacuum eliminates convection as a mode of heat transfer inside of the vacuum vessel, enhancing our ability to achieve exquisite thermal stability.

Design considerations for the vacuum chamber include:

- Weight – Although strength per unit weight between aluminum and steel are similar, when buckling is considered for our vacuum vessel, the larger wall thickness of the aluminum offered equivalent performance at approximately 2000 kg weight savings. Considering the increased wall thickness, the resultant in-plane conductivity of an aluminum chamber is $\sim 20X$ greater than a stainless steel chamber. The overall effect is improved temperature uniformity across the surface of the vacuum vessel.
- Structural rigidity, especially in the areas where the science camera's rear sections interface to the vacuum vessel wall. Although the rear and front camera sections (housing the detectors) are decoupled via a flexible bellows, the bellows does have a stiffness coefficient and changes in vacuum wall displacement with normal atmospheric pressure fluctuations will influence the spectrograph.

Analysis of recorded weather data at Las Campanas Observatory found that 99.9% of daily pressure variations are 10 mbar or less. Our structural, thermal and optical performance (STOP) model results verified the system can withstand a 10 mbar pressure variation and still remain within specification.

- Maximizing access for installation of the bench and optics as well as subsequent adjustment/alignment of optical elements during integration.
- Minimizing O-ring linear seal length such that the chamber can maintain a minimum vacuum level of 4×10^{-4} Torr or lower through an entire observing night with the main pumping system off. ConFlat copper gaskets will be used where practical and Ion pumps will be implemented to maintain vacuum level long-term.

Figure 9 shows G-CLEF inside of our cylindrical vacuum chamber.



Figure 9 – Cylindrical Vacuum Chamber Concept with Section View

2.3.5 Thermal Control System

The performance goal of the thermal control system is to maintain the bench and all optics to a thermal stability of ± 0.001 °C for the operational life of the instrument. We selected a target temperature close to our expected lab assembly temperature of 20 °C. In order to achieve maximum temperature stability, we selected a multi-layer approach as shown schematically in figure 10. The bench and optics reside within the vacuum chamber with an intermediate radiation shield between the bench and vacuum chamber wall. Surrounding the vacuum chamber is an array of thermal control panels; basically 3mm thick sheets of aluminum covered with Kapton strip heaters. The panels completely surround the vacuum chamber and themselves have a 25mm thick layer of insulation on the side opposite the vacuum chamber. This insulation layer serves to reduce in-plane temperature gradients across the face of each control panel. The panels are held to 20 °C ± 0.005 °C with commercially available measurement and proportional integral derivative (PID) control hardware. Outside of the thermal control panels is a layer of conditioned air held at 17.5 °C ± 0.5 °C. This serves as a bias temperature ensuring that once steady state temperature is reached, all heat applied to the panels ultimately flows outward. Outside of the conditioned air is a layer of scavenged air drawn away via an additional shroud into the GMT air handling exhaust system. Its purpose is to ensure that the thermal emission into the GMT dome is minimized.

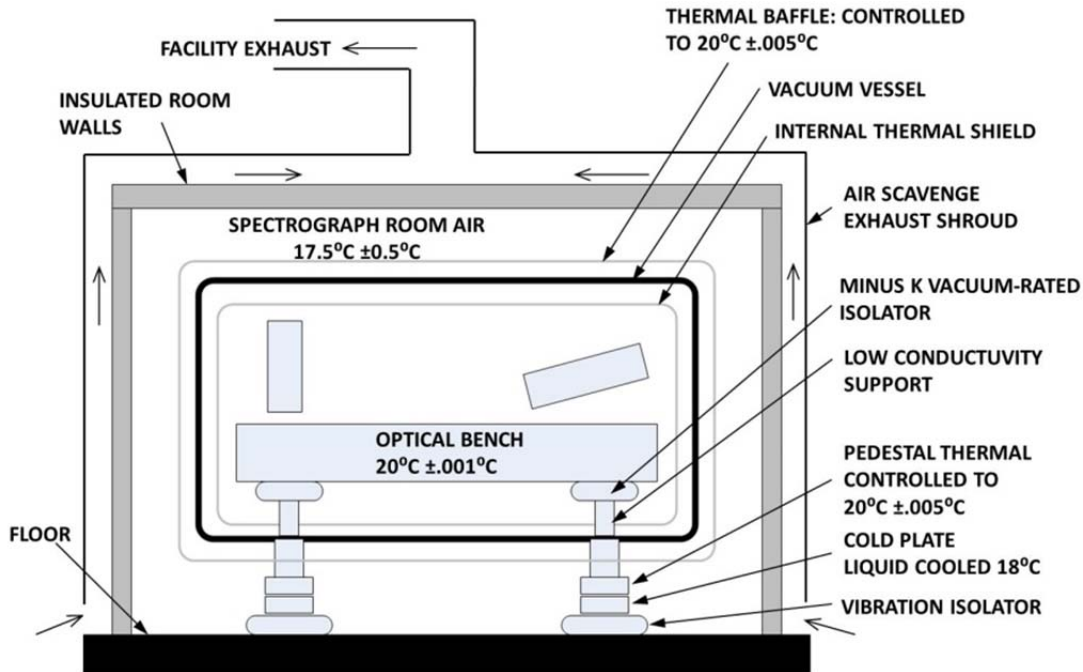

Figure 10 – Thermal Control Schematic

Conduction through the vacuum chamber support legs will be controlled in a similar manner, by establishing a lower bias temperature and ensuring that heat flows outward only.

We constructed a 1/5th scale thermal prototype to validate our control scheme. The test set up is shown in figure 11.



Figure 11 – Thermal Prototype Set-Up Showing our Scaled Vacuum Chamber, Thermal Panel Assemblies and Isotech Precision Measurement Electronics

It consists of an aluminum target mass in a cylindrical aluminum vacuum vessel. Temperature measurement of the exterior thermal panels, vacuum chamber walls and target mass is done using Isotech MicroK™ measurement electronics and glass bead resistance temperature detectors (RTD's)⁸. Six 3mm thick aluminum panels heated with nine Kapton tape resistance heaters each surround the vacuum chamber. Using this set-up and after some tuning of the software control loop, we were able to demonstrate thermal control to 0.25 milli-K-per-day stability levels. With refinement, we assess that stability levels much better than this are feasible. This prototype validated our measurement system selections and control algorithms, as well as provided useful data on the heat loads for the insulated panels and important information for establishing temperature, power, and insulation requirements for the G-CLEF instrument. We also learned that well engineered solutions to control conduction through mounting feet, vacuum hoses and electrical

feed-throughs are a must. This scaled system appears to be tolerant of bias temperature variation in excess of 2°C (+/- 1 °C). This sets the error range of the HVAC system which controls the layer of air surrounding the heater panels on the full sized instrument.

The red and blue focal planes each have thermal stability requirements for extreme PRV similar to those of the bench but with the added challenge of operation at -110°C. We plan to cool each focal plane using an LN₂-fed Continuous Flow Cryocooler (CFC) system. We have purchased a SuperTran™ CFC system from Janis Research to characterize cooling performance, refine control algorithms, and expose any reliability issues during long-term operation⁹.

2.3.6 Vacuum Chamber Support Assembly and Vibration Isolation System

The entire vacuum chamber assembly will be installed within the vacuum chamber on a support system which incorporates vibration isolators and a self-leveling system. We allocated a 3% impact on image resolution in PRV mode due to vibration. This yields a vibration image motion requirement of 5 μm root-mean square (RMS) vibration contribution in dispersion direction (roughly 0.0125 G's).

We will implement Aeroflex isolators at the three mounting feet sized to provide 3.25 to 5.4 Hz natural frequency. These wire coil isolators provide 3.5 to 5X transmissibility at system natural frequency and 3% or less transmissibility at bench resonant frequency (50 Hz). They will be used in conjunction with a self-leveling system (a single actuator at each of the two rear feet). Seismic snubbers will be implemented to limit displacement during an earthquake. The support system with isolators and self-leveling mechanisms is shown below in figure 12.

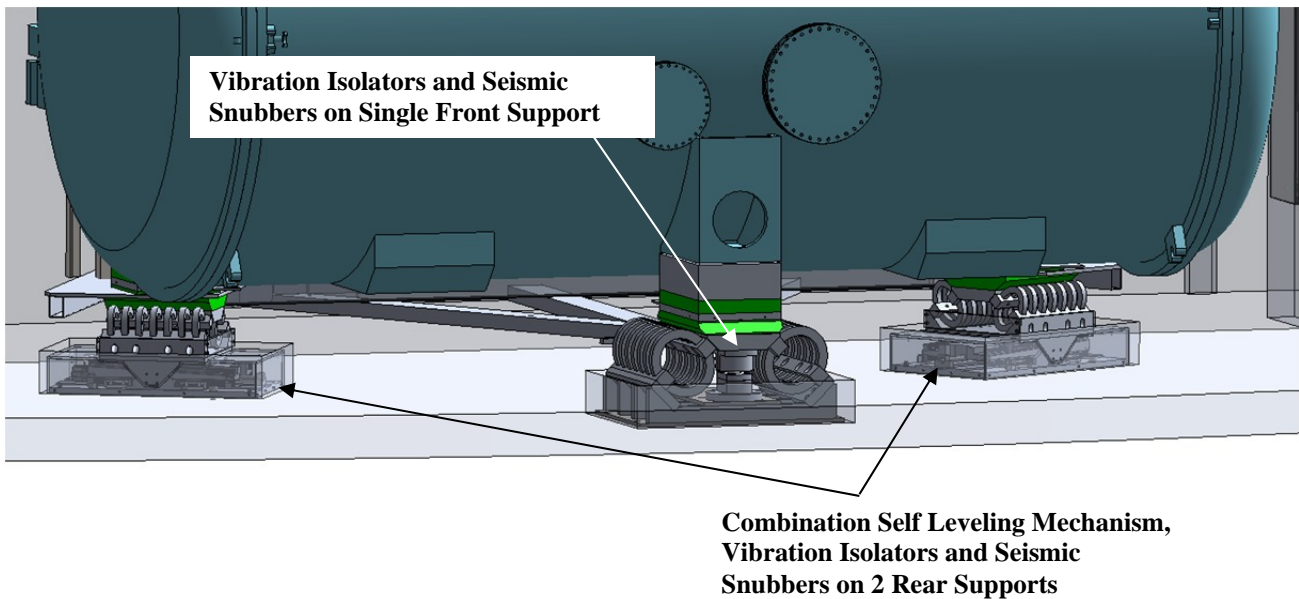

Figure 12 – Vacuum Vessel Support System

The transmissibility curve for the Aeroflex isolators is shown in figure 13.

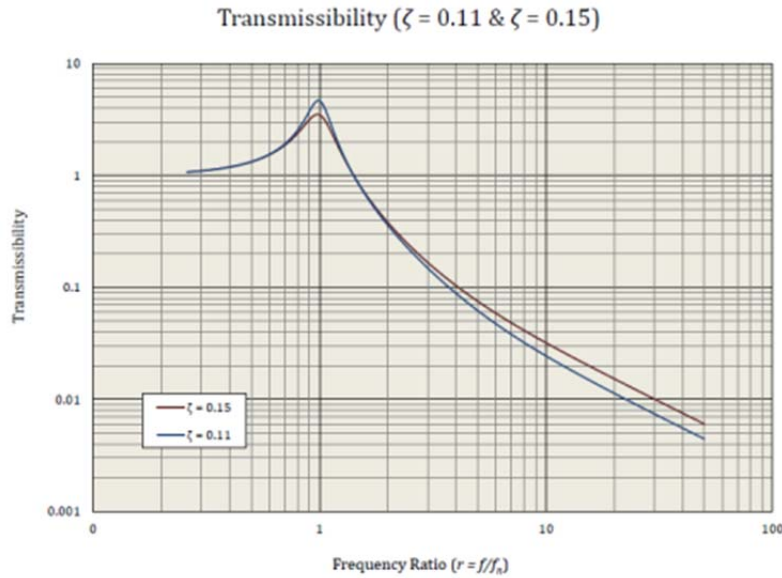

Figure 13 – Aeroflex Isolator Transmissibility Curve

2.3.7 Calibration Systems

G-CLEF will utilize two calibration systems. A lamp based system will be designed and built by the KASI. The function of this subsystem will be to feed two separate optical calibration fibers from the light sources listed in table 2. Figure 14 shows the calibration light source (CLS) packaged in a standard electronics cabinet (SEC) along with its location on GMT's auxiliary utility platform (AUP). Internal light sources are located in the CLS and internal mechanisms allow two optical calibration fiber heads to move in front of any of the light sources. Each individual light source can be independently viewed by both fiber assemblies. Calibration fibers will be routed up to the G-CLEF front end via our fiber run.

Table 2- List of Calibration Light Sources

#	Light Source	Location	Purpose/Comment
1	Low Current ThAr HCL	Internal	Wavelength calibration.
2	High Current ThAr HCL	Internal	Wavelength calibration.
3	High Current Spare ThAr HCL	Internal	Spare for high current HCL's.
4	Incandescent lamp	Internal	Pixel-to-pixel variation mapping/flat fielding, and order tracing.
5	Laser supercontinuum source (Energetiq lamp)	External	Pixel-to-pixel variation mapping/flat fielding and order tracing.
6	Laser frequency comb	External	Ultra-precise wavelength calibration, PSF characterization and correction of CCD photolithography.
7	Etalon	External	Precise wavelength calibration and PSF characterization.

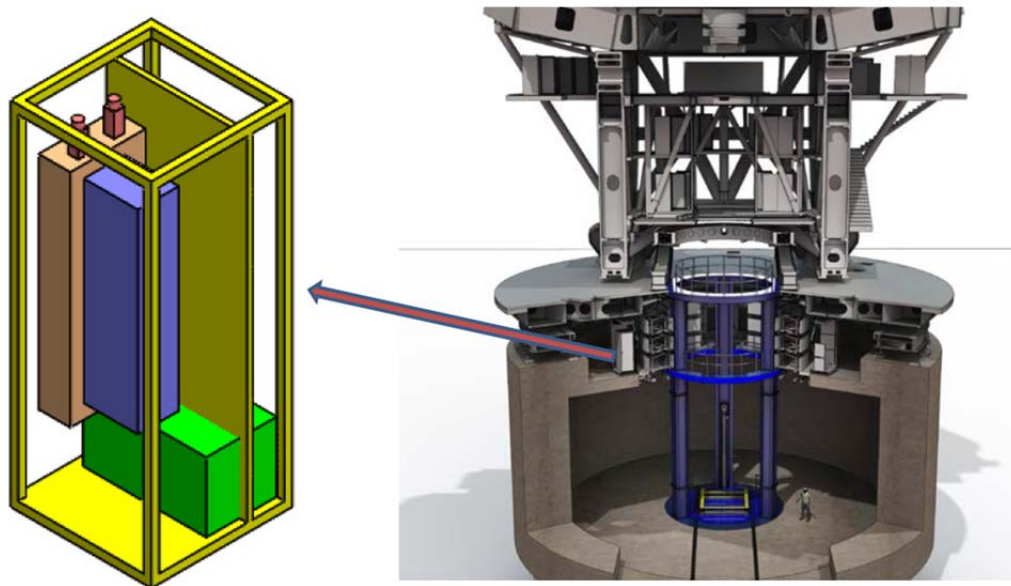

Figure 14 – Calibration Light Source in a Standard Electronics Cabinet Located on GMT’s Auxiliary Utility Platform

In addition to the KASI CLS, G-CLEF will employ a laser Optical Frequency Synthesizer similar to the model FC1000 unit produced by MenloSystems¹⁰. The unit consists of an optical bench portion which will be located in the temperature controlled environment of our thermal enclosure and the electronics portion which will be reconfigured to fit within an SEC. This SEC will also be located on GMT’s auxiliary utility platform. The FC1000 unit is shown in figure 15.

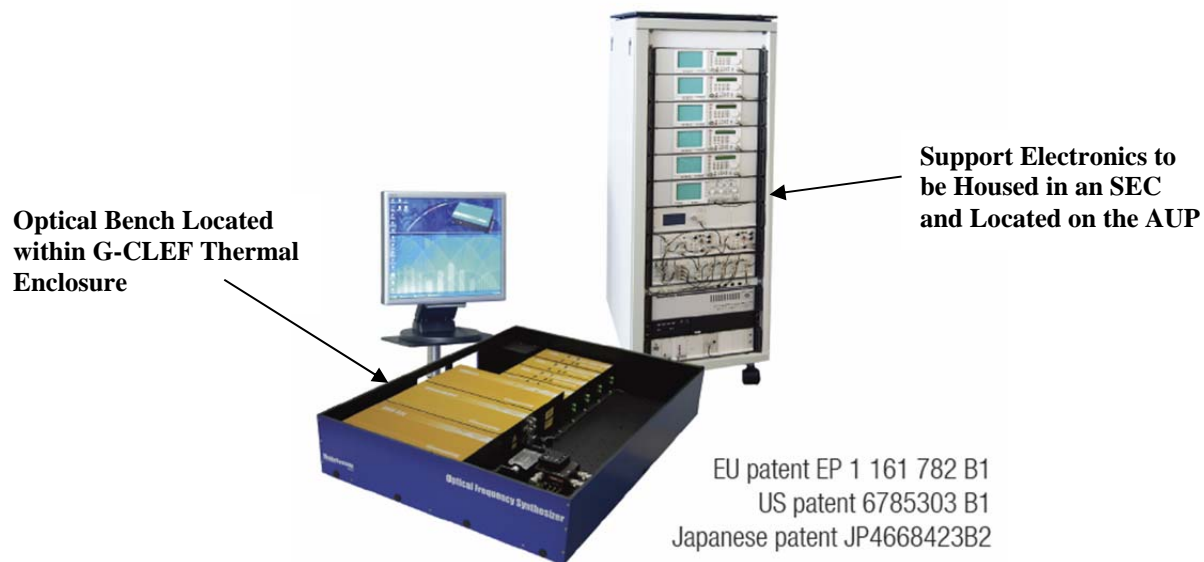

Figure 15 – Model FC1000 Optical Frequency Synthesizer Produced by Menlo Systems

2.3.8 Auxiliary Systems

G-CLEF will require several auxiliary systems placed either near the spectrograph or at the Auxiliary Utility Platform just below GMT's Azimuth Disk. These systems include:

- a.) Thermal control electronics
- b.) Dewars and/or cryogen support hardware
- c.) Vacuum control hardware and electronics

2.4 Significant Design Challenges

2.4.1 Thermal Control of the Spectrograph and Science Camera Assemblies

Measurement errors could be present as a result of time varying temperature gradients in the spectrograph optical bench. They cause thermo-elastic distortions of the spectrograph optical system which in turn shifts the spectra on the detector and changes the focus. These errors are low frequency relative to measurement duration and, therefore, can be calibrated to a certain extent. We have built and continue to maintain a high fidelity system-level STOP model to predict system level performance and it's response to changes in a variety of design variables.

Results of our thermal analysis using our latest design with composite bench (CTE = -0.1 ppm/C) and Invar optical mounts (CTE = 1.3 ppm/C) are shown in Table 3.

Table 3 - Summary of G-CLEF CDR STOP Model Results

Load Case	Image Motion at Detector (IMAD) in Dispersion, Angstroms		
	Red IMAD	Blue IMAD	SE Budget
Thermal Soak +0.001 °C	3.33	1.18	5.4
Vertical Gradient	0.22	1.47	3.2
Lateral Gradient	5.41	4.16	7.8
Lengthwise Gradient	0.93	0.24	---

While we are confident in our overall temperature control scheme, there are two details that must be watched closely. They are:

- Science camera CCD cooling
- Thermal conduction through the vacuum vessel support system and all service feed-throughs

The science CCD must be cooled to an operational temperature of -110 °C (163K) with a level of thermo-mechanical stability on par with the rest of the instrument. We are planning to implement a SuperTran® continuous flow cryo-cooler from Janis Research on each science camera assembly¹⁰. A system has been procured for characterization during the CDR phase for evaluation.

The vacuum vessel supports and all service feed-throughs will have independently controlled thermal guard heaters to prevent parasitic heat transfer into or out of the vacuum chamber and bench assembly.

2.4.2 Mechanical Stability

Mechanical instability of the optical system can be categorized into three types of errors:

- i. Changes in atmospheric pressure (external to the spectrograph) cause structural deformation of the vacuum housing which can print through to the spectrograph, resulting in lateral shifts of the spectra as well as focus errors.
- ii. Motion of the G-CLEF spectrograph support structure (floor) as the telescope moves in azimuth, results in lateral shifts of the spectra and focus errors.
- iii. Instability of the materials in the spectrograph over a measurement interval.

These error terms affect both calibration and star light and are expected to be small and vary slowly compared to measurement times, and are thus considered calibratable. These effects are amenable to analysis, which is ongoing in the Critical Design Phase.

The effect of a 10 mBar pressure variation is a load case that is continuously considered when evaluating changes to the vacuum chamber, optical bench and all support mechanisms.

The current structural model predicts that alignment errors on the Azimuth axis of the telescope can subject the instrument to hundreds of micro-g's as the telescope tracks. These effects can cause image motion in the dispersion direction as much as ten times allowable for these motions. Our solution will be to implement a self-leveling system to eliminate the variation in the gravity vector caused by telescope tracking.

A CME analysis of the composite bench was performed in the PDR phase and we concluded that this effect was both trendable and significantly diminished after approximately 100 days within our vacuum system. Total dimensional change of the bench over the life of the instrument is expected to be less than 50 microns which should not appreciably affect spectrograph performance.

2.4.3 Grating Mosaic Mounting and Alignment

As indicated earlier, G-CLEF's optical design features a grating mosaic of three 300mm X 400mm grating facets which must be mounted and aligned relative to one another to tight tolerance. Surfaces must be parallel to one another within approximately 1 μ m, and tip/tilt about axis' normal to the grating surface must also be aligned to less than 1 μ m across the length of each edge. This is a significant but manageable challenge that we will address with a proper measurement scheme, mount design and alignment fixturing.

2.4.4 Optical Mounts and Optics Handling

Optical mounts are never to be taken lightly, however, given the environment within the spectrograph (temperature and gravity invariant), operational loads are quite benign. The most severe load conditions the optics will experience are due to handling and shipment. These are well understood and the mount configuration, along with all handling and shipping fixtures, will be designed accordingly. Positioning tolerances of optics will typically be in the 12 to 25 micron range. While tight, we have achieved such tolerances regularly on MMIRS and Binospec using our Opticentric™ lens mounting system.

2.4.5 Weight

The various G-CLEF subsystems must conform to a GMTO defined weight budget. Variances are not out of the question but must be approved. Our current projected and approved weight allocation is as follows:

- a. Spectrograph on azimuth disk = 14500 kg
- b. Support equipment on auxiliary utility platform = 1200 kg
- c. Front end assembly ~ 1300 kg total for fixed IP and moving GIR sections

2.4.6 System Transport and Shipment

Shipping conditions (in the form of temperature variation and expected shock loading) are proving to be the design drivers for most critical components, namely the optical mounts. Controlling the shipping conditions will allow us to simplify mount design for a net savings in cost and complexity. Our instrument will have to endure international travel by either sea or air in order to reach the GMT in Chile. We are researching both air and sea options and are finding that a variety of temperature control options are available. Extreme temperature excursions combined with moderate to high shock loads can be particularly dangerous to bonded optical mounts. Also of concern is shipment of the composite bench which combines large size and mass with bonded joints.

We are confident that suitable methods of shipment are available but we will likely have to ship the spectrograph's major optical assemblies as discrete items; shock isolated and temperature controlled. A shipment and re-integration plan will be presented as part of CDR.

3. CONCLUSIONS

We are designing and building the G-CLEF instrument using current design-engineering best practices guided by rigorous systems engineering methodology. Requirements definition, flow down, verification and error budgeting are integral to the process. This approach is in conformance with the GMT requirements process and is consistent with the approach being utilized to design and build the GMT itself. We have identified the major design challenges and are addressing them with a combination of innovative design approaches, analysis and prototyping efforts. We are confident that the G-CLEF team is on track to present a robust critical design as scheduled in May 2017.

REFERENCES

- [1] Szentgyorgyi, A., et al., "The GMT-Consortium Large Earth Finder (G-CLEF): An Optical Echelle Spectrograph for the Giant Magellan Telescope (GMT), Proc. SPIE, 9908-76, (2016).
- [2] Jacoby, G., Bernstein, R., Bouchez, A., Colless, M., DePoy, D., Espeland, B., Jaffe, D., Lawrence, J., Marshall, J., McGregor, P. Sharp, R., Szentgyorgyi, A. and Walls, B., "Instrumentation Progress at the Giant Magellan Telescope project," Proc. SPIE, 9908-68 (2016).
- [3] Fűrész, G. et al., "The G-CLEF Spectrograph Optical Design: An Update to the White Pupil Echelle Configuration", Proc. SPIE, 9147, (2014).
- [4] Johns, M., McCarthy, et al., "Overview and status of the Giant Magellan Telescope Project", Proc. SPIE, 9906-37, (2016)
- [5] Podgorski, W. A., et al., "A Novel Systems Engineering Approach to the Design of a Precision Radial Velocity Spectrograph - the GMT-Consortium Large Earth Finder (G-CLEF)", Proc. SPIE, 9147-333 (These proceedings), (2014).
- [6] Cohen, L. M., "Effects of Temporal Dimensional Instability on the Advanced X-ray Astrophysics Facility (AXAF-I) High Resolution Mirror Assembly (HRMA)"
- [7] Opticentric™ is a product of Trioptics USA, 2223 West San Bernardino Road, West Covina, CA 91790 USA
- [8] Isotech North America is located at 158 Brentwood Drive, Unit 4 Colchester, VT 05446
- [9] SuperTran™ is a product of Janis Research Company, 225 Wildwood Avenue, Woburn, MA 01801-2025 USA
- [10] Menlo Systems Inc. is located at 56 Sparta Avenue, Newton, NJ 07860